

50 Hz



TLCN, TLCHN Series

WET ROTOR CIRCULATORS
FOR SANITARY SYSTEMS

Cod. 191027201 Rev. B Ed.12/2014

 **LOWARA**
a xylem brand

**TCLN, TLCHN SERIES
INSTALLATION POSITIONS**

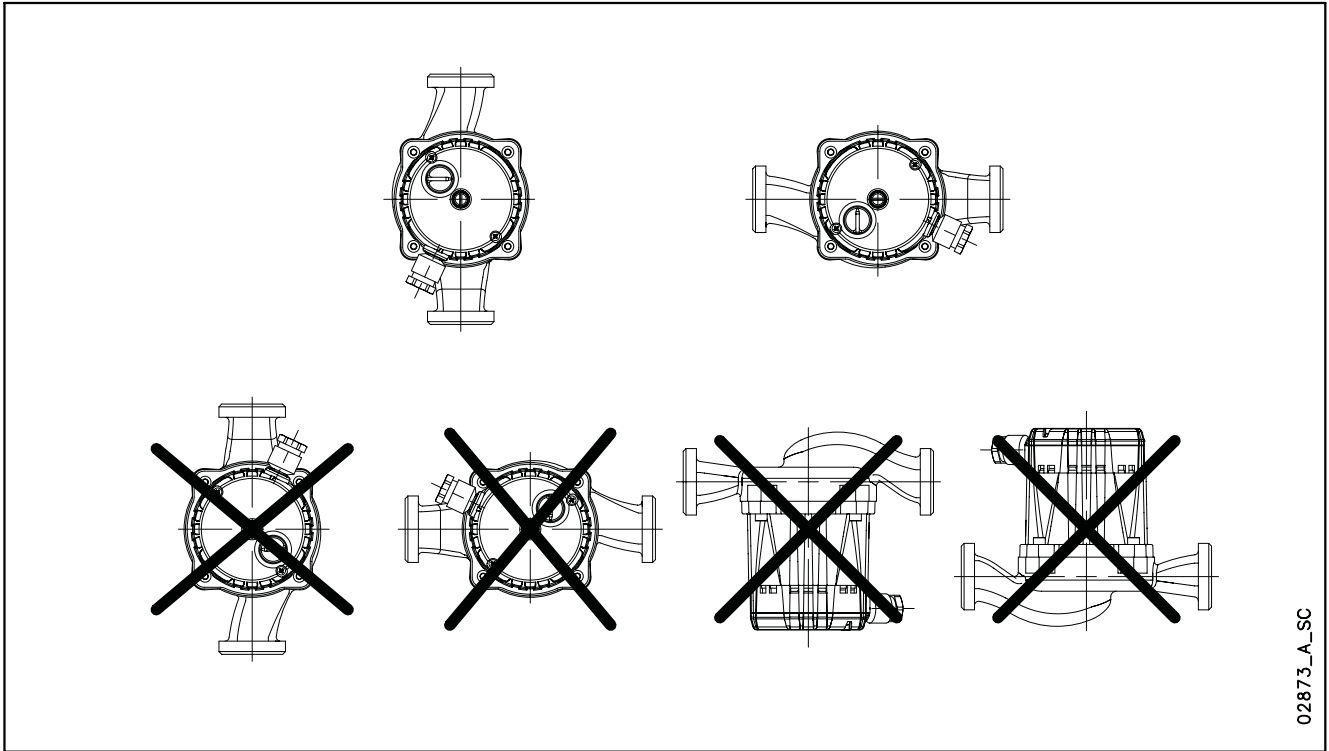

02873_A_SC

Sanitary Circulators

MARKET SECTORS

RESIDENTIAL.

APPLICATIONS

- Circulation of sanitary hot water.

TLCN Series



SPECIFICATIONS

PUMP

- **Flow rate:** up to 4 m³/h.
- **Head:** up to 6 m.
- **Temperature of pumped liquid:** +2°C ÷ +110°C (recommended up to 65°C). Avoid condensation and ice formation.
- **Maximum operating pressure:** 10 bar (PN 10).
- **Impeller:** made of composite material.
- **Wear ring:** ceramic.

MOTOR

- Wet rotor type, with bearings lubricated by the pumped liquid. Axial and radial bearings made of ceramic.
- Single-phase 230 V 50 Hz power supply. Terminal box axially integrated in the motor.
- Three speed hand selector motor.
- **Insulation class** 180 (H).
- **Protection class** IP 44.

CONSTRUCTION CHARACTERISTICS

- Electric circulator pumps for sanitary hot water circulation, at a recommended maximum temperature of 65°C, maximum hardness of 25° f (14°dH) and maximum viscosity of 10 mm²/s.
- Stainless steel pump body with 1", 1" ¼ and 1" ½ threaded connections.
- According to EN standards 60335-1, 60335-2-51, 55014-1, 55014-2.

ACCESSORIES

- Pipe unions.
- Insulation shell.

INSTALLATION

- Suitable for installation in horizontal or vertical piping, in any position provided that motor axis is horizontal.

TLCN SERIES IDENTIFICATION CODE

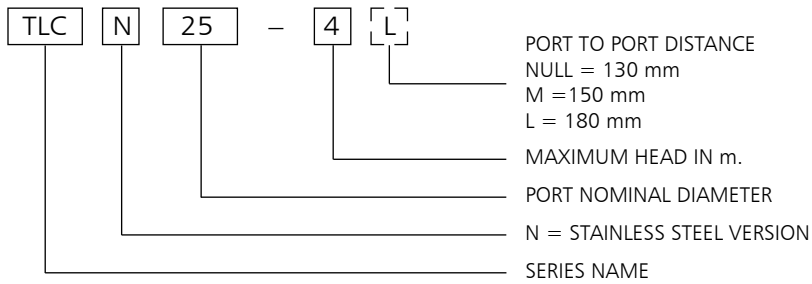

EXAMPLE : TLCN 25-4L

TLC series circulator, stainless steel N version, port nominal diameter = 25, max head= 4 m, with port to port distance of 180 mm.

TABLE OF MATERIALS

PART	MATERIAL
Pump body	Stainless steel
Impeller	Composite material
Shaft	Ceramic
Inner jacket	Stainless steel
Wear ring	Ceramic
Bearings	Ceramic
Gaskets	EPDM

t1cn-2p50-en_a_tm

Regulations (EC) n. 641/2009 and (EU) n. 622/2012 – Annex I – point 2 (Product information requirements)

- a) Energy efficiency index: note not applicable to these products.
- b) "The benchmark for most efficient circulators is $EI \leq 0,20$ ": note not applicable to these products.
- c) Information relevant for disassembly, recycling or disposal at end-of-life: observe the current laws and by-laws governing sorted waste disposal. Consult the product operating manual.
- d) Information for circulators specifically designed to potable water uses: "This circulator is suitable for drinking water only".

TLCN SERIES HYDRAULIC PERFORMANCE TABLE

PUMP TYPE	MAXIMUM ABSORBED POWER W	MAXIMUM ABSORBED CURRENT A	CAPACITOR		SPEED	Q = DELIVERY											
						l/s 0	0,2	0,3	0,4	0,5	0,7	0,8	1,0	1,2			
						m ³ /h 0	0,6	1,2	1,5	1,8	2,4	3,0	3,6	4,2			
230V 50Hz			μ F	V		H = TOTAL HEAD METRES COLUMN OF WATER											
TLCN 15-2.5	27	0,12	1,5	400	1	2,1	2,0	1,5	1,3	1,0							
TLCN 20-2.5M	32	0,14			2	2,3	2,1	1,7	1,5	1,2							
TLCN 25-2.5	35	0,15			3	2,5	2,3	1,9	1,7	1,4	0,8						
TLCN 15-4	33	0,14	1,5	400	1	3,5	2,7	1,8	1,4	1,1							
TLCN 20-4M	39	0,17			2	3,9	3,2	2,5	2,1	1,8	1,1						
TLCN 25-4 (L)	44	0,19			3	4,1	3,5	2,8	2,5	2,1	1,4						
TLCN 15-6	43	0,19	2,0	400	1	3,4	2,3	1,5	1,1	0,9							
TLCN 20-6M	65	0,28			2	5,1	4,1	3,0	2,5	2,0	1,1						
TLCN 25-6 (L)	80	0,34			3	6,2	5,5	4,7	4,3	3,9	3,0	2,1	1,2				

Hydraulic performances in compliance with ISO 9906:2012 - Grade 3B (ex ISO 9906:1999 - Annex A)

tlcn-2p50-en_b_th

TLCN SERIES SINGLE-PHASE OPERATING CHARACTERISTICS

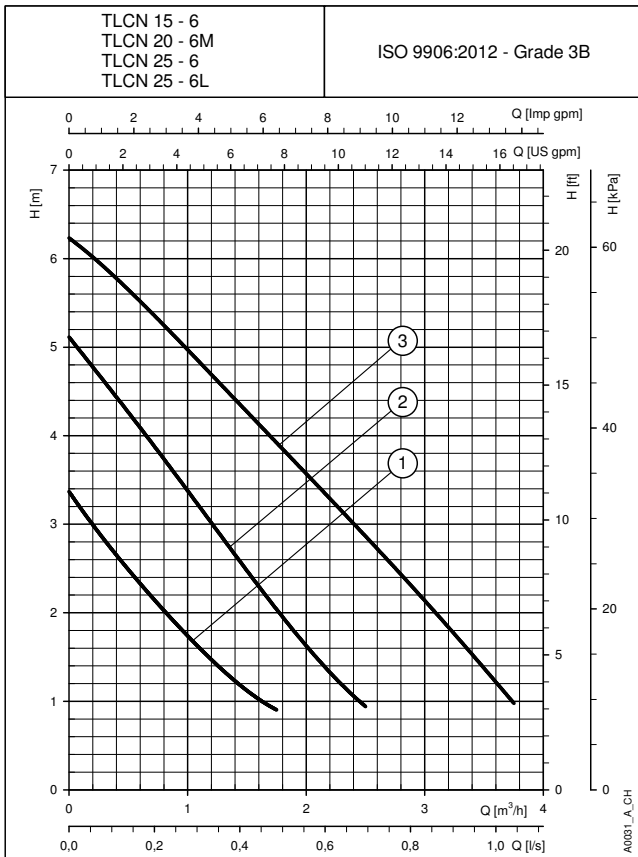
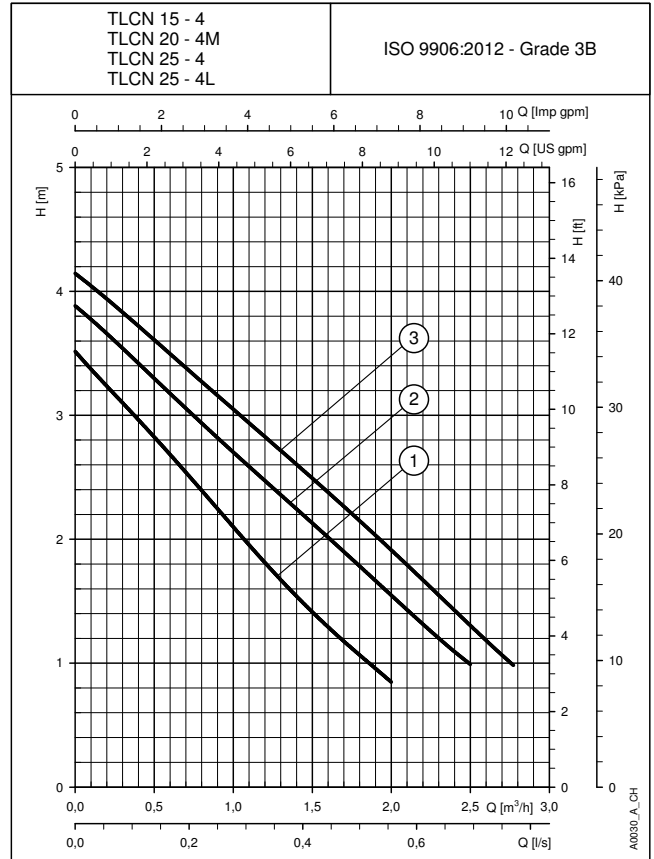
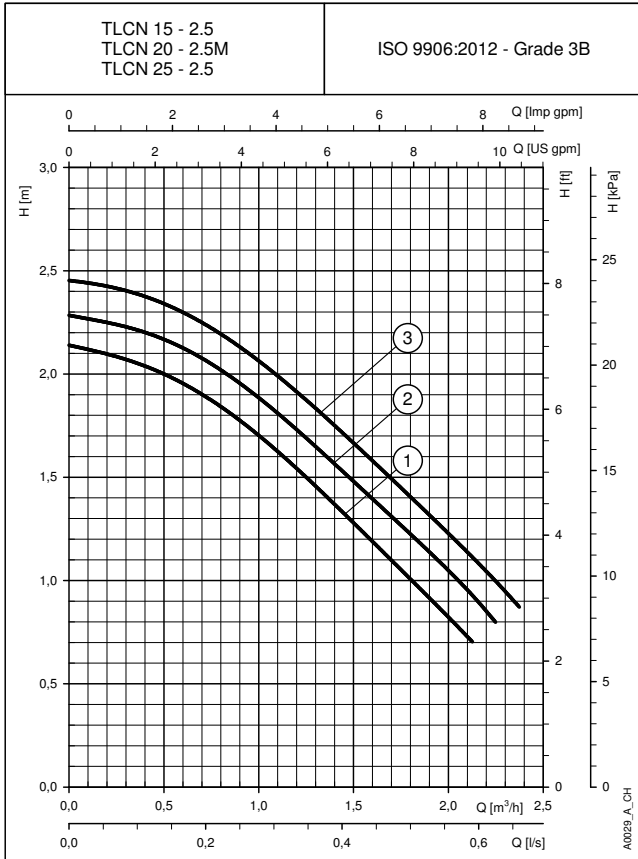

These performances are valid for liquids with density $\rho = 1.0 \text{ Kg/dm}^3$ and kinematic viscosity $\nu = 1 \text{ mm}^2/\text{sec}$.

TLCN SERIES DIMENSIONS AND WEIGHTS

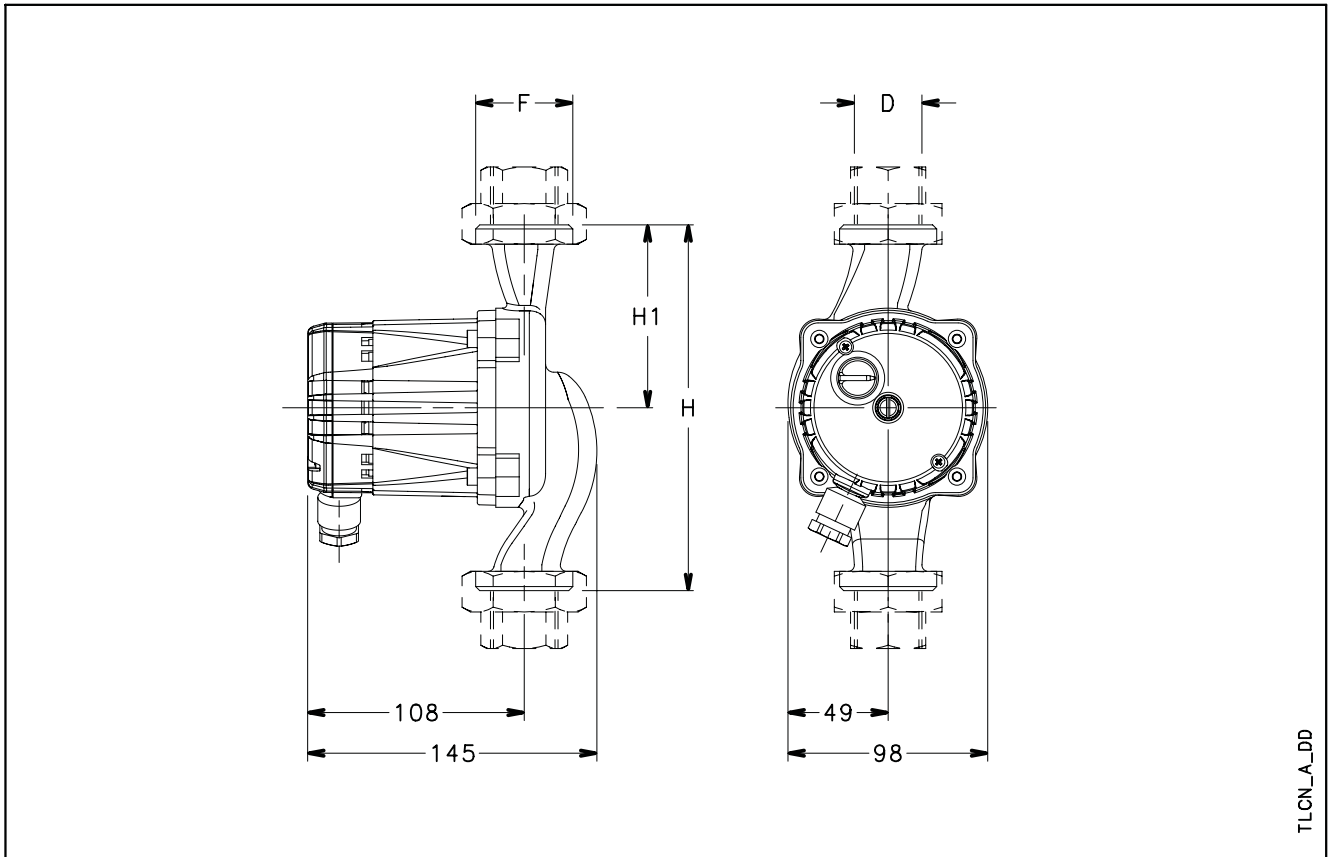

DIMENSIONS AND WEIGHTS TABLE

PUMP TYPE	DIMENSIONS (mm)					WEIGHT kg
	H	H1	D	F	DN	
TLCN 15-2.5	130	65	1/2"	G 1"	15	2,7
TLCN 20-2.5M	150	75	3/4"	G 1 1/4"	20	2,7
TLCN 25-2.5	130	65	1"	G 1 1/2"	25	2,7
TLCN 15-4	130	65	1/2"	G 1"	15	2,7
TLCN 20-4M	150	75	3/4"	G 1 1/4"	20	2,7
TLCN 25-4	130	65	1"	G 1 1/2"	25	2,7
TLCN 25-4L	180	90	1"	G 1 1/2"	25	2,8
TLCN 15-6	130	65	1/2"	G 1"	15	2,7
TLCN 20-6M	150	75	3/4"	G 1 1/4"	20	2,7
TLCN 25-6	130	65	1"	G 1 1/2"	25	2,7
TLCN 25-6L	180	90	1"	G 1 1/2"	25	2,8

tfcn-2p50-en_a_td

Sanitary Circulators

MARKET SECTORS
SANITARY LIGHT COMMERCIAL.

APPLICATIONS

- Circulation of sanitary hot water in high flow/high head installations.

TLCHN Series



SPECIFICATIONS

PUMP

- **Flow rate:** up to 12 m³/h.
- **Head:** up to 12 m.
- **Temperature of pumped liquid:** +2°C ÷ +110°C (recommended up to 65°C). Avoid condensation and ice formation.
- **Maximum operating pressure:** 10 bar (PN 10).
- **Impeller:** made of composite material.
- **Wear ring:** ceramic.

MOTOR

- Wet rotor type, with bearings lubricated by the pumped liquid. Axial and radial bearings made of ceramic.
- Single-phase 230 V 50 Hz power supply. Terminal box axially integrated in the motor.
- Three speed hand selector motor.
- **Insulation class** 180 (H).
- **Protection class** IP 44.

CONSTRUCTION CHARACTERISTICS

- Electric circulator pumps for sanitary hot water circulation, at a recommended maximum temperature of 65°C, maximum hardness of 25° f (14°dH) and maximum viscosity of 10 mm²/s.
- Stainless steel pump body with 1" 1/4 and 1" 1/2 threaded connections.
- According to EN standards 60335-1, 60335-2-51, 55014-1, 55014-2.

ACCESSORIES

- Pipe unions.
- Insulation shell.

INSTALLATION

- Suitable for installation in horizontal or vertical piping, in any position provided that motor axis is horizontal.

TLCHN SERIES IDENTIFICATION CODE

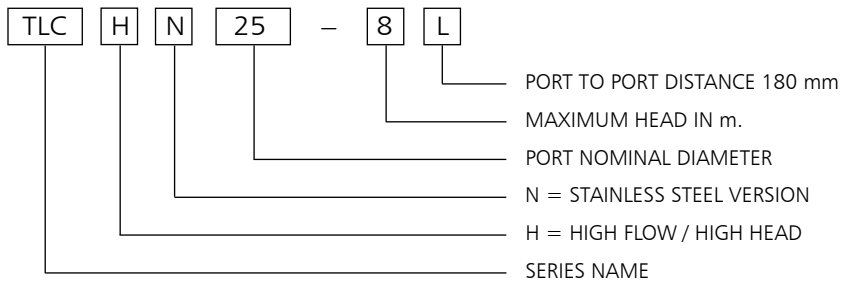

EXAMPLE : TLCHN 25-8L

TLC series circulator, high flow/head H version, stainless steel N version, port nominal diameter = 25, max head= 8 m, with port to port distance of 180 mm.

TABLE OF MATERIALS

PART	MATERIAL
Pump body	Stainless steel
Impeller	Composite material
Shaft	Ceramics
Inner jacket	Stainless steel
Wear ring	Ceramics
Bearings	Ceramics
Gaskets	EPDM

tlchn-2p50-en_a_tm

Regulations (EC) n. 641/2009 and (EU) n. 622/2012 – Annex I – point 2 (Product information requirements)

- Energy efficiency index: note not applicable to these products.
- "The benchmark for most efficient circulators is $EI \leq 0,20$ ": note not applicable to these products.
- Information relevant for disassembly, recycling or disposal at end-of-life: observe the current laws and by-laws governing sorted waste disposal. Consult the product operating manual.
- Information for circulators specifically designed to potable water uses: "This circulator is suitable for drinking water only".

TLCHN SERIES HYDRAULIC PERFORMANCE TABLE

PUMP TYPE	MAXIMUM ABSORBED POWER W	MAXIMUM ABSORBED CURRENT A	CAPACITOR		SPEED	Q = DELIVERY								
						l/s 0	0,3	0,7	1,0	1,3	1,7	2,0	2,3	2,7
						m ³ /h 0	1,2	2,4	3,6	4,8	6,0	7,2	8,4	9,6
230V 50Hz			μ F	V		H = TOTAL HEAD METRES COLUMN OF WATER								
TLCHN 20-7L	220	1,03	8,0	400	1	5,8	5,2	4,3	3,1	2,0	1,0			
TLCHN 25-7L	228	1,04			2	6,7	6,1	5,4	4,4	3,3	2,1	1,2		
	260	1,13			3	7,1	6,7	6,1	5,2	4,2	3,3	2,4	1,5	
TLCHN 20-8L	260	1,23	8,0	400	1	6,6	5,5	4,2	2,8	1,6	0,8			
TLCHN 25-8L	270	1,24			2	7,5	6,9	6,1	4,9	3,6	2,4	1,4		
	286	1,25			3	8,0	7,5	6,8	5,8	4,6	3,5	2,5	1,6	
TLCHN 20-10L	283	1,35	8,0	400	1	8,3	6,9	5,0	2,9	1,1				
TLCHN 25-10L	343	1,44			2	9,4	8,7	7,7	6,3	4,7	3,1	1,7		
	357	1,56			3	10,1	9,6	8,8	7,7	6,5	5,2	3,9	2,6	1,6
TLCHN 20-12L	285	1,36	8,0	400	1	7,7	6,5	4,4	2,2	0,7				
TLCHN 25-12L	372	1,69			2	10,3	9,7	8,4	6,9	5,2	3,5	1,8		
	400	1,73			3	12,0	11,4	10,4	9,2	7,8	6,2	4,7	3,2	2,0

Hydraulic performances in compliance with ISO 9906:2012 - Grade 3B (ex ISO 9906:1999 - Annex A)

tlchn-2p50-en_a_th

TLCHN SERIES SINGLE-PHASE OPERATING CHARACTERISTICS

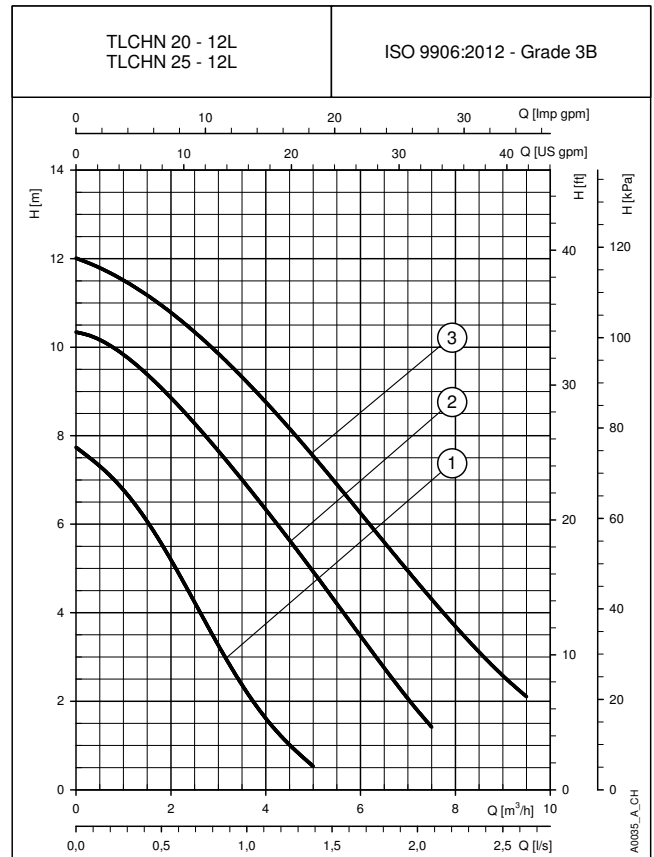
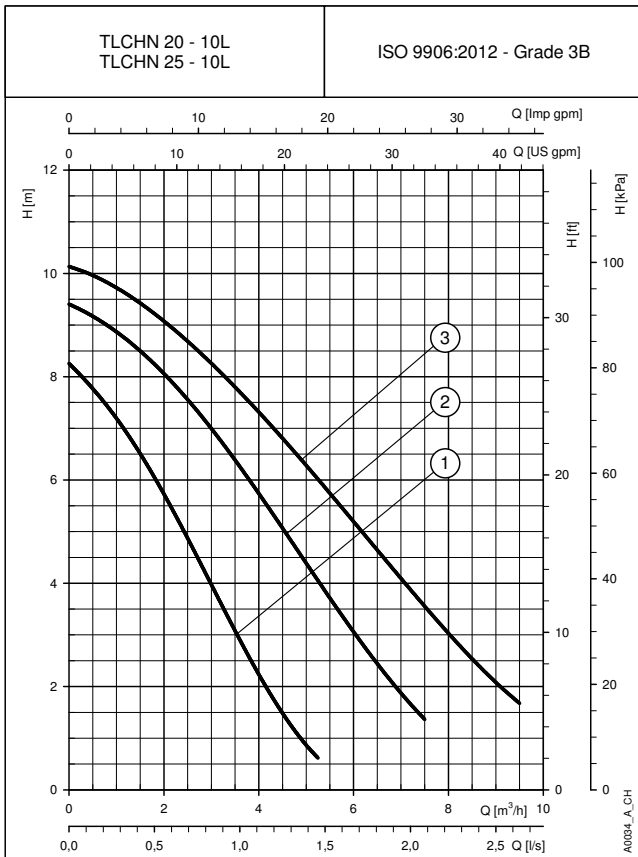
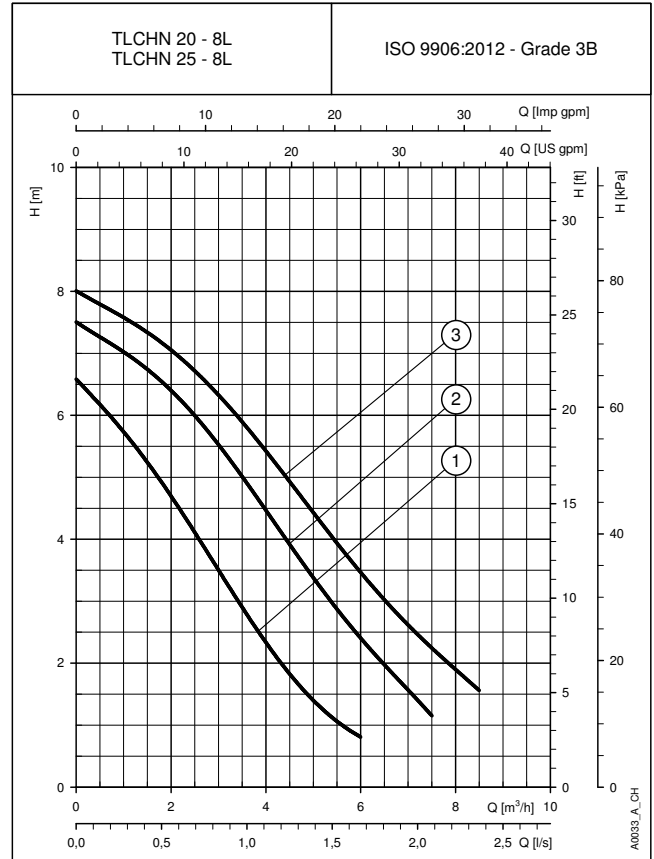
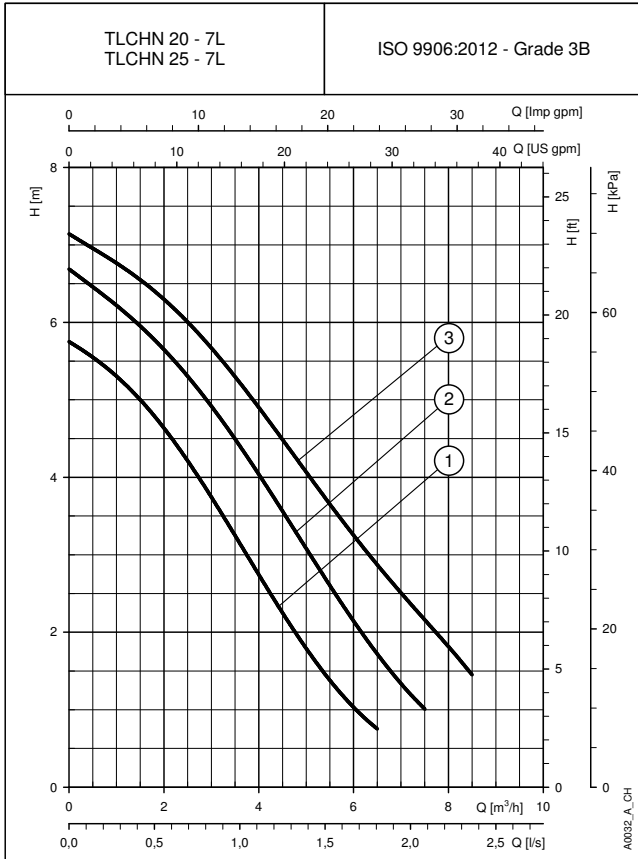

These performances are valid for liquids with density $\rho = 1.0 \text{ Kg/dm}^3$ and kinematic viscosity $\nu = 1 \text{ mm}^2/\text{sec}$.

TLCHN SERIES DIMENSIONS AND WEIGHTS

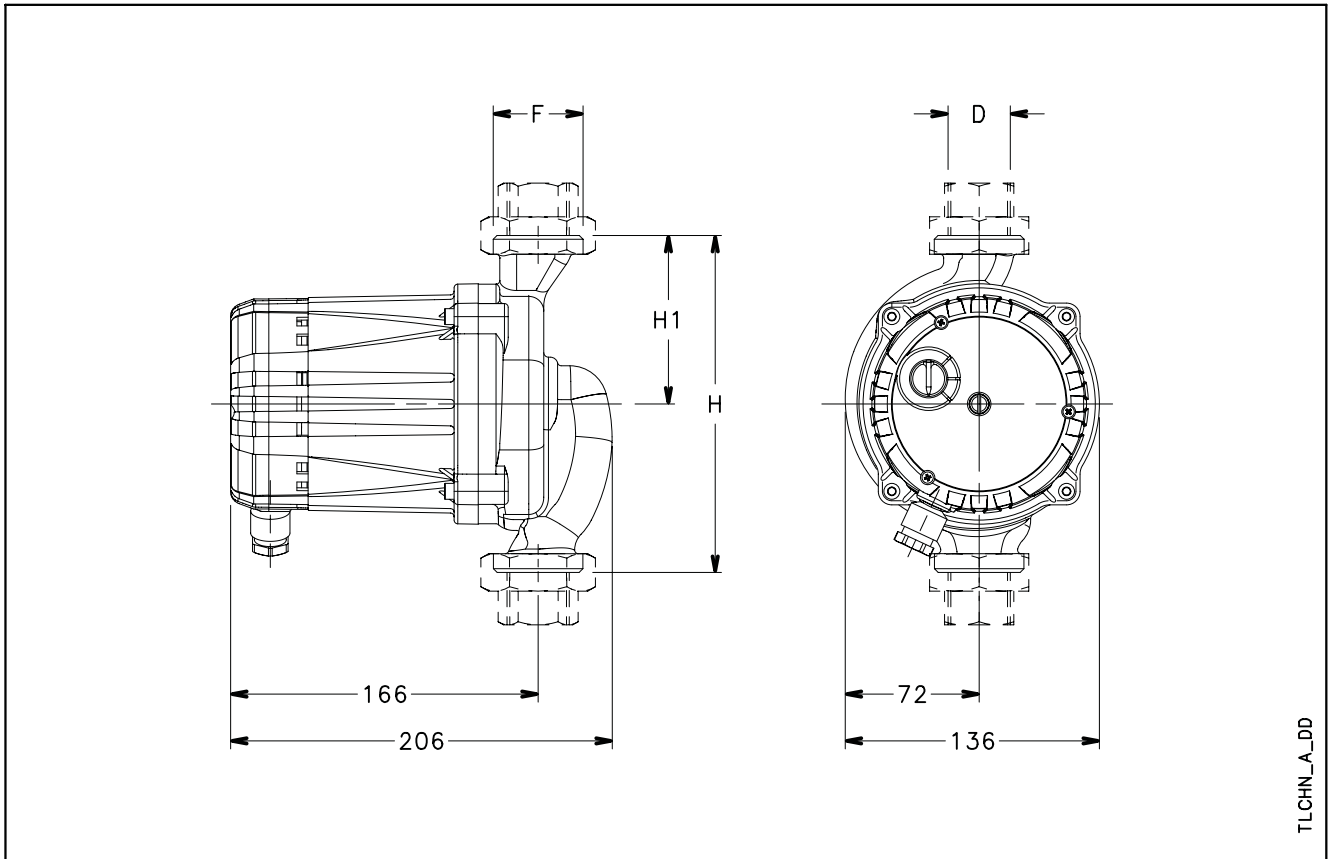

TLCHN_A_DD

DIMENSIONS AND WEIGHTS TABLE

PUMP TYPE	DIMENSIONS (mm)					WEIGHT kg
	H	H1	D	F	DN	
TLCHN 20-7L	180	90	¾"	G 1"¼	20	6,5
TLCHN 25-7L	180	90	1"	G 1"½	25	6,5
TLCHN 20-8L	180	90	¾"	G 1"¼	20	6,5
TLCHN 25-8L	180	90	1"	G 1"½	25	6,5
TLCHN 20-10L	180	90	¾"	G 1"¼	20	6,5
TLCHN 25-10L	180	90	1"	G 1"½	25	6,5
TLCHN 20-12L	180	90	¾"	G 1"¼	20	6,5
TLCHN 25-12L	180	90	1"	G 1"½	25	6,5

tlchn-2p50-en_a_td

DOCUMENTATION

FURTHER PRODUCT SELECTION AND DOCUMENTATION Xylect™

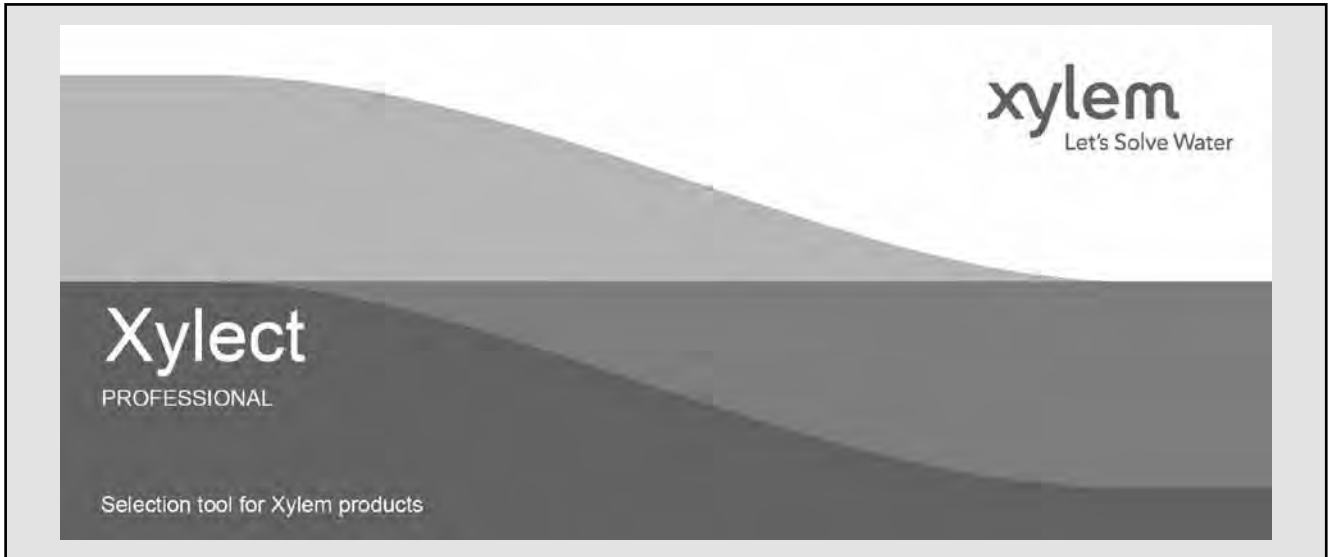

Xylect™ is pump solution selection software with an extensive online database of product information across the entire Lowara, and Vogel range of pumps and related products, with multiple search options and helpful project management facilities. The system holds up-to-date product information on thousands of products and accessories.

The possibility to search by applications and the detailed information output given makes it easy to make the optimal selection without having detailed knowledge about the Lowara and Vogel products.

The search can be made by:

- Application
- Product type
- Duty point

Xylect™ gives a detailed output:

- List with search results
- Performance curves (flow, head, power, efficiency, NPSH)
- Motor data
- Dimensional drawings
- Options
- Data sheet printouts
- Document downloads incl dxf files

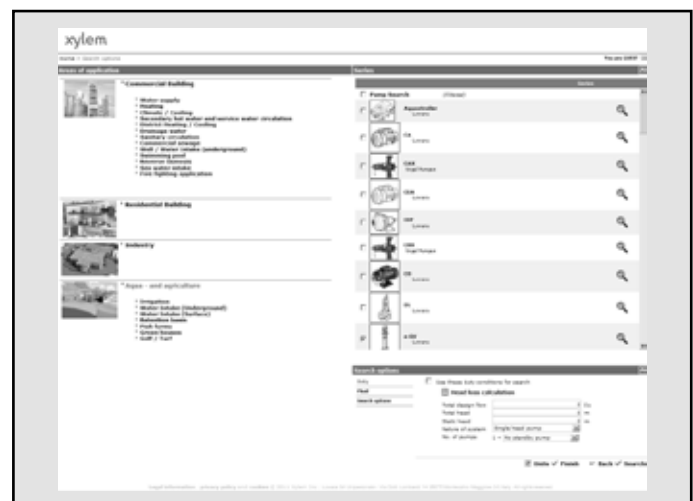

The search by application guides users not familiar with the product range to the right choice.

FURTHER PRODUCT SELECTION AND DOCUMENTATION Xylect™

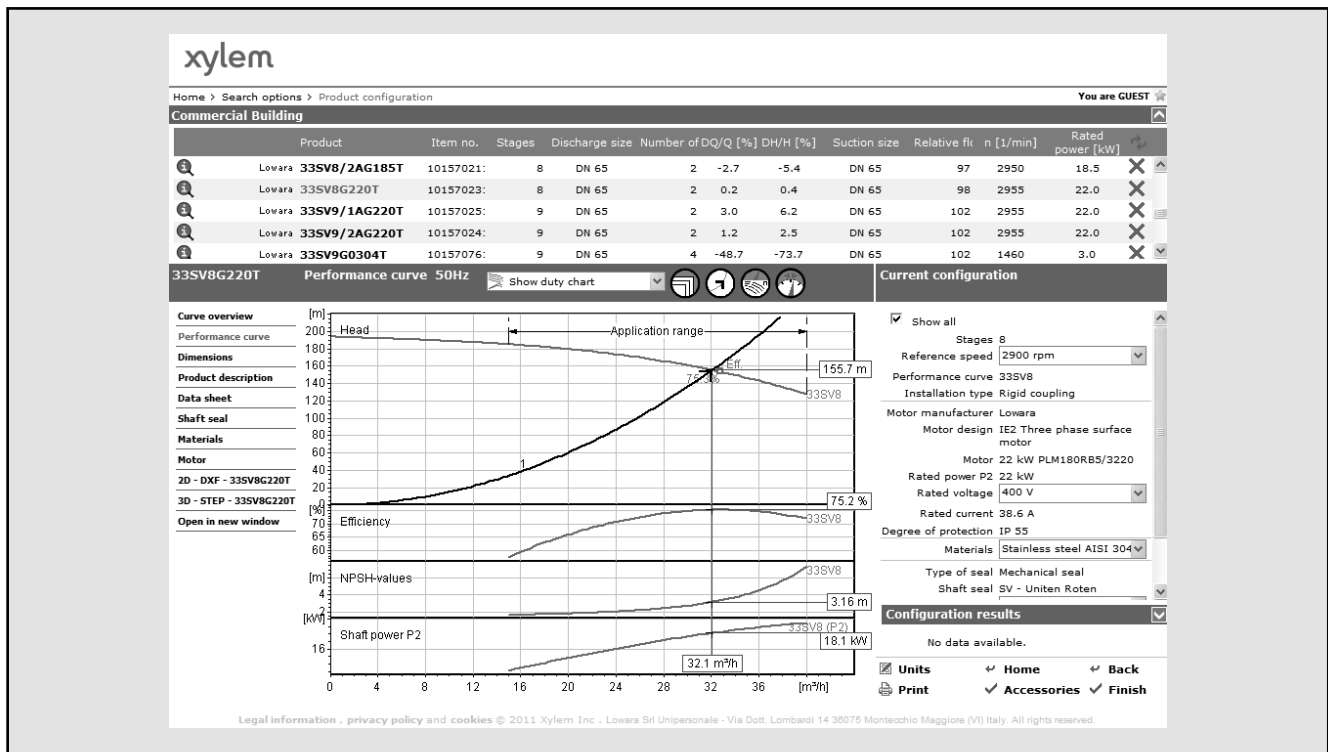

The detailed output makes it easy to select the optimal pump from the given alternatives.

The best way to work with Xylect™ is to create a personal account. This makes it possible to:

- Set own standard units
- Create and save projects
- Share projects with other Xylect™ users

Every user has a My Xylect space, where all projects are saved.

For more information about Xylect™ please contact our sales network or visit www.xylect.com.

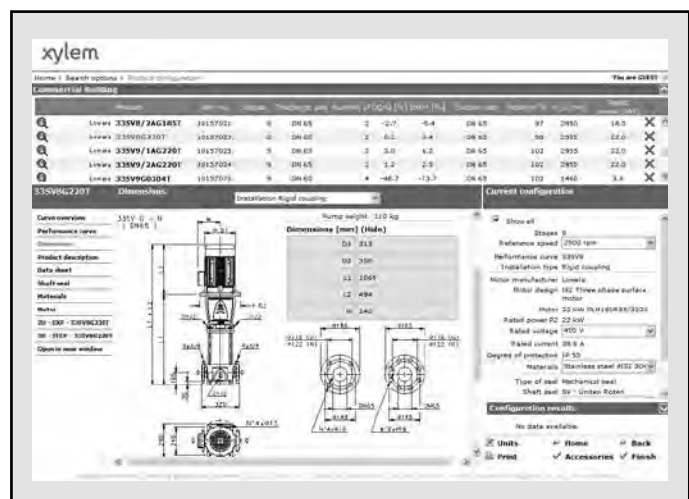

Dimensional drawings appear on the screen and can be downloaded in dxf format.



ООО «Бауманс Груп» - официальный партнер завода Lowara в России.

Тел: +7 495 121 49 50

Эл. почта: info@baumgroup.ru

Сайт: www.baumgroup.ru